



« 1995 Continental Table of Contents »

«Group 01: BODY»

«Section 01-20B: Restraints, Passive--Supplemental Air Bag System»

«DIAGNOSIS AND TESTING»

Print Diagnostic Routine

DTC 12: LOST BATTERY FEED

Normal Operation

The air bag diagnostic monitor measures the voltage at Pin C1-14 of the air bag diagnostic monitor connector. Voltage at Pin C1-14 should be equal to battery voltage. If the voltage at Pin C1-14 drops to less than 8 volts, the air bag diagnostic monitor will flash a DTC 12 on the AIR BAG indicator. If the voltage at Pin C1-14 drops to less than 5 volts, the DTC 12 will also be stored in memory. Should the loss of battery voltage at Pin C1-14 be intermittent or repaired, the air bag diagnostic monitor will flash a DTC 52 (or higher priority code if one exists) on the next ignition switch cycle.

Possible Causes

WARNING:

UNDER NO CIRCUMSTANCES SUBSTITUTE ANOTHER FUSE VALUE. ANY FUSE OTHER THAN 10A MAY CAUSE DISARMING FAILURE AND MAY RESULT IN DANGER TO THE OCCUPANTS OF THE VEHICLE. DO NOT ATTEMPT TO REPLACE THE 10A FUSE UNLESS THE AIR BAG SYSTEM FIRST HAS BEEN DEACTIVATED (REFER TO DEACTIVATION PROCEDURE FOR DETAILS).

NOTE:

If a short to ground exists on any of the Circuits 607 (LB/O), 614 (GY/O), 615 (GY/W), or 616 (PK/BK) leading to a DTC 13 or 53, or similarly a short to ground exists on any of Circuits 617 (PK/O), 619 (PK/W), 624 (Y/W), 625 (Y/LG) leading to a DTC 14 or 54, the air bag diagnostic monitor will activate a solid state switch at Pin C1-13 of the air bag diagnostic monitor. This causes the 10 amp battery fuse to blow, thus disarming the air bag system and preventing inadvertent air bag deployment. If the 10 amp fuse junction panel (or power distribution box in some vehicles) battery fuse has blown, it **must** be replaced by a 10A fuse.

Low voltage at air bag diagnostic monitor Pin C1-14 can be caused by:

- **An open in the battery circuit** that would prevent B+ from reaching air bag diagnostic monitor Pin C1-14.
- **A short to ground on the battery feed circuit** between the fuse and Pin C1-13 or Pin C1-14 of the air bag diagnostic monitor.
- **A concern in the charging system** causing battery voltage to drop below 8 volts.

After the air bag diagnostic monitor has disarmed the air bag system, it will not be enabled to disarm again until the appropriate condition (DTC 13, 14, 53, or 54) has been serviced and cleared (refer to «[DTC 13](#)» , «[14](#)» , «[53](#)» , and «[54](#)» and «[Diagnostic Trouble Code Clearing](#)» descriptions for further details).

Electrical Schematic--Diagnostic Trouble Code 12

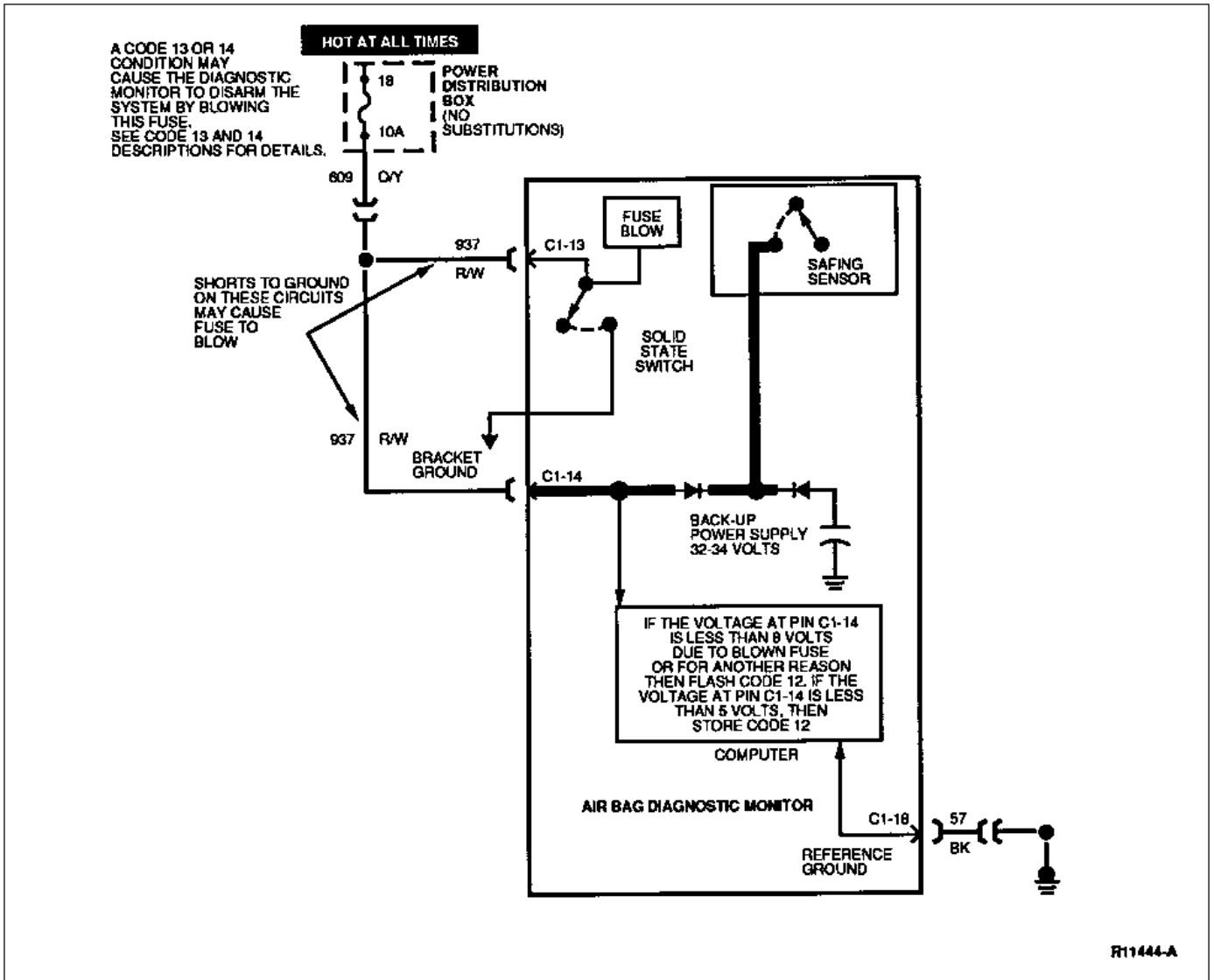

- ➡ 12-1: UNDERSTAND FUNCTION
- ➡ 12-2: CHECK CHARGING SYSTEM
- ➡ 12-3: CHECK BATTERY FEED
- ➡ 12-4: CHECK BATTERY FUSE
- ➡ 12-5: CHECK FOR SHORT IN HARNESS
- ➡ 12-6: CONFIRM CONDITION



« 1995 Continental Table of Contents »

«Group 01: BODY»

«Section 01-20B: Restraints, Passive--Supplemental Air Bag System»

«DIAGNOSIS AND TESTING»

Print Diagnostic Routine

Pre-Diagnostic Information

DTC 12: LOST BATTERY FEED

12-1 UNDERSTAND FUNCTION

- Cycle the ignition switch to OFF and then to RUN and confirm that DTC 12 is flashing on the air bag indicator.
- Read the normal operation description for DTC 12.
- Examine the diagnostic trouble code schematic.
- **Is the diagnostic trouble code operation well understood?**

Yes

NOTE: This is a hard fault. The fault condition is still present. This fault may not be cleared until it is serviced and flashes out as a DTC 52.

GO to «12-2».

No

RE-EXAMINE appropriate descriptions and schematics. Failure to understand air bag system functions will result in needless replacement of system components and repeat service.



« 1995 Continental Table of Contents »

«Group 01: BODY»

«Section 01-20B: Restraints, Passive--Supplemental Air Bag System»

«DIAGNOSIS AND TESTING»

Print Diagnostic Routine

Pre-Diagnostic Information

DTC 12: LOST BATTERY FEED

12-2 CHECK CHARGING SYSTEM

- Measure charging system voltage.
- Is voltage greater than 8 volts?

Yes

GO to «12-3».

No

SERVICE vehicle charging system. CYCLE ignition switch. PROCEED to the description, schematic, and pinpoint tests of the diagnostic trouble code that is flashing.



« 1995 Continental Table of Contents »

«Group 01: BODY»

«Section 01-20B: Restraints, Passive--Supplemental Air Bag System»

«DIAGNOSIS AND TESTING»

Print Diagnostic Routine

Pre-Diagnostic Information

DTC 12: LOST BATTERY FEED

12-3 CHECK BATTERY FEED

- Deactivate system.
- Disconnect air bag diagnostic monitor.
- Turn ignition switch from OFF to RUN.
- Measure voltage between air bag diagnostic monitor harness connector Pins C1-14 (+) and C1-18 (-).
- **Is voltage on Pin C1-14 equal to B+?**

Yes

REPLACE air bag diagnostic monitor. RECONNECT system. VERIFY system. REACTIVATE system.

No

GO to «12-4».



« 1995 Continental Table of Contents »

«Group 01: BODY»

«Section 01-20B: Restraints, Passive--Supplemental Air Bag System»

«DIAGNOSIS AND TESTING»

Print Diagnostic Routine

Pre-Diagnostic Information

DTC 12: LOST BATTERY FEED

12-4 CHECK BATTERY FUSE

- Check 10A battery fuse feeding air bag diagnostic monitor harness connector Pins C1-14 and C1-13.
- Check power distribution fuse feeding the 10A fuse.
- **Is either fuse blown?**

Yes

GO to «12-5».

No

LOCATE and SERVICE open Circuit 609 (O/Y) or 937 (R/W) between positive (+) terminal of battery and Pin C1-14 of the air bag diagnostic monitor harness connector. Check in-line connectors, crimps, etc. CONNECT air bag diagnostic monitor. CYCLE ignition switch. PROCEED to the description, schematic, and pinpoint tests of the diagnostic trouble code that is flashing.



« 1995 Continental Table of Contents »

«Group 01: BODY»

«Section 01-20B: Restraints, Passive--Supplemental Air Bag System»

«DIAGNOSIS AND TESTING»

Print Diagnostic Routine

Pre-Diagnostic Information

DTC 12: LOST BATTERY FEED

12-5 CHECK FOR SHORT IN HARNESS

WARNING:

CERTAIN FAULT CONDITIONS (DIAGNOSTIC CODE 13/53 OR 14/54) MAY CAUSE THE AIR BAG DIAGNOSTIC MONITOR TO INTENTIONALLY BLOW THE 10A BATTERY FUSE TO DISARM THE AIR BAG SYSTEM. DO NOT SUBSTITUTE ANOTHER FUSE VALUE FOR THE 10A BATTERY FUSE. ANY OTHER FUSE VALUE MAY CAUSE FUTURE DISARMING FAILURE AND MAY RESULT IN DANGER TO THE OCCUPANTS OF THE VEHICLE. ONCE THE AIR BAG DIAGNOSTIC MONITOR HAS DISARMED THE SYSTEM, IT WILL NOT ATTEMPT TO DO SO AGAIN UNTIL THE APPROPRIATE DIAGNOSTIC TROUBLE CODE (13/53 OR 14/54) HAS BEEN CLEARED. THUS DO NOT REACTIVATE SYSTEM UNTIL ALL DIAGNOSTIC TROUBLE CODES HAVE BEEN REPAIRED AND CLEARED.

- Replace blown fuse. NO SUBSTITUTIONS.
- Does fuse blow again?

Yes

LOCATE and SERVICE short to ground in Circuit 609 (O/Y) or 937 (R/W) between fuse and Pin C1-13 or Pin C1-14 of the air bag diagnostic monitor harness connector. CONNECT air bag diagnostic monitor. CYCLE ignition switch. PROCEED to the description, schematic, and pinpoint tests of the diagnostic trouble code that is flashing.

No

GO to «12-6».



« 1995 Continental Table of Contents »

«Group 01: BODY»

«Section 01-20B: Restraints, Passive--Supplemental Air Bag System»

«DIAGNOSIS AND TESTING»

Print Diagnostic Routine

Pre-Diagnostic Information

DTC 12: LOST BATTERY FEED

12-6 CONFIRM CONDITION

- Reconnect air bag diagnostic monitor
- **Does fuse blow again?**

Yes

REPLACE air bag diagnostic monitor. REPLACE fuse, NO SUBSTITUTIONS. RECONNECT system. VERIFY system. REACTIVATE system.

No

CYCLE ignition switch. PROCEED to the description, schematic, and pinpoint tests of the diagnostic trouble code that is flashing.
